

Jongen Werkzeugtechnik GmbH & Co. KG

# T-Slot Milling Cutter 90TN-...

for the creation of T-slots  
made to DIN 650

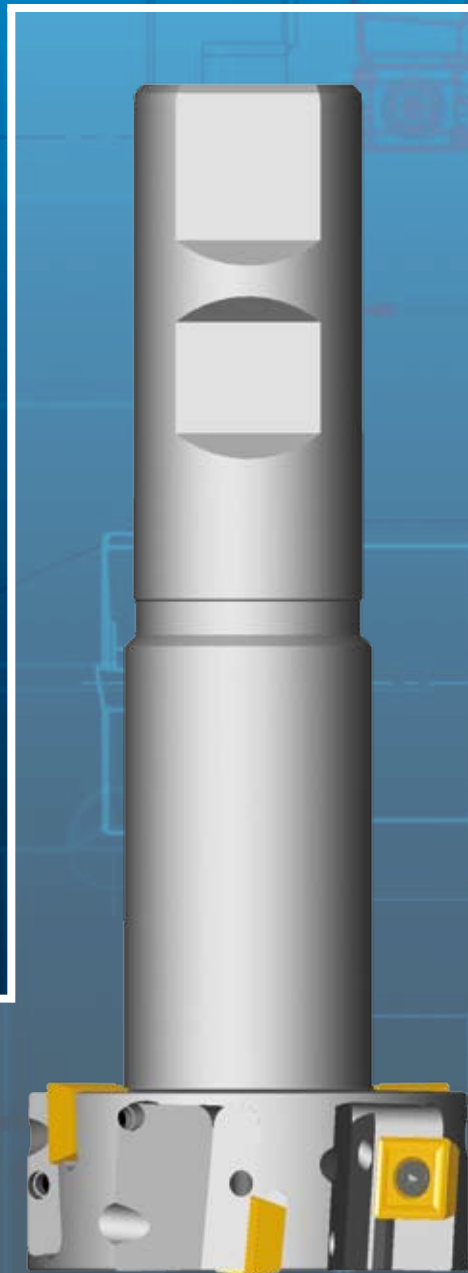

## TOOL DESCRIPTION

- Jongen UNI-Mill T-slot milling cutter 90TN-... has been developed for the creation of T-slots made to DIN 650
- Applicable to all current materials
- All tools incl. internal coolant feed or coolant channels
- Coupling made to DIN 1835-B

## APPLICATION EXAMPLES

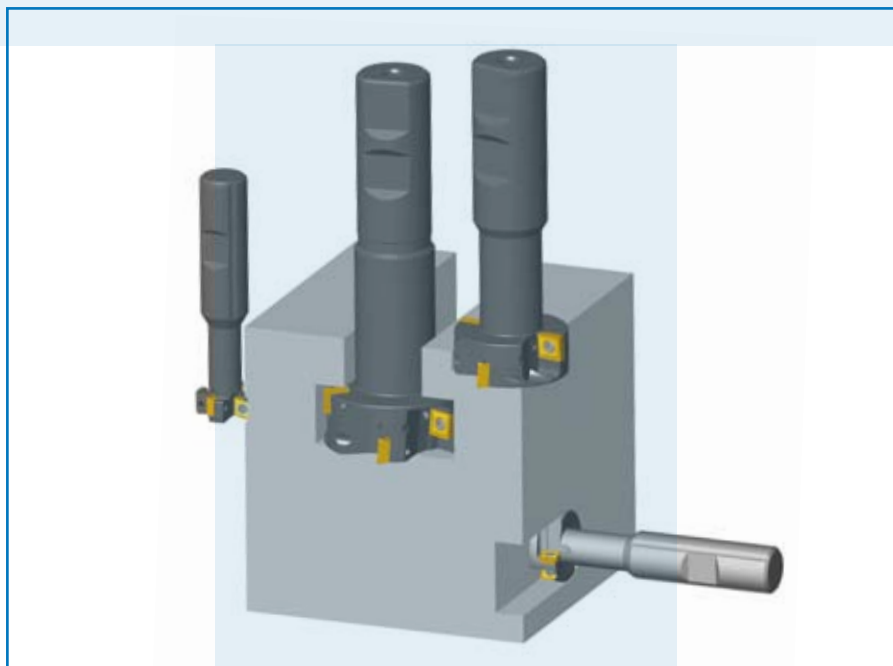

## TECHNICAL DATA

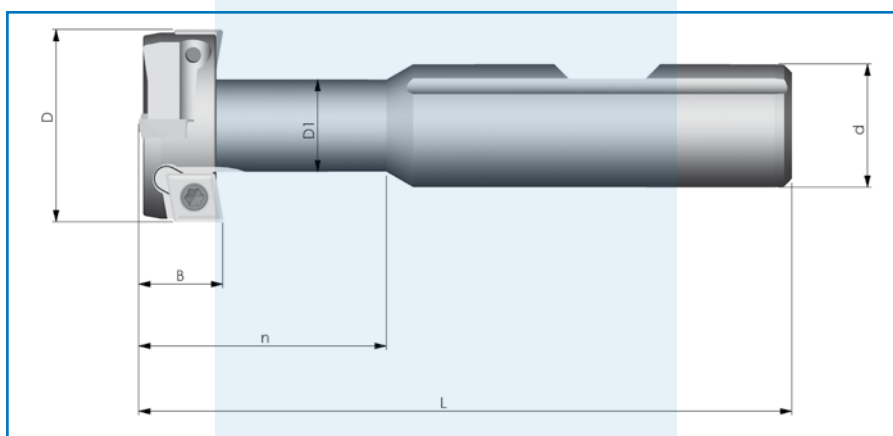

Order-No.	D	D1	B	L	n	d	ZZ	Z
90TN-21-09-65-2	21	11	9	85	32	16	2	4
90TN-25-11-65-2	25	12	11	85	32	16	2	4

## INSERTS

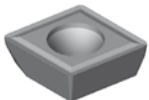
 6,35x6,35x2,36 r=0,4	<b>FP 65</b> (B9)	Application areas: 1 - 6 (see page 4)
--	----------------------	---------------------------------------

## TECHNICAL DATA

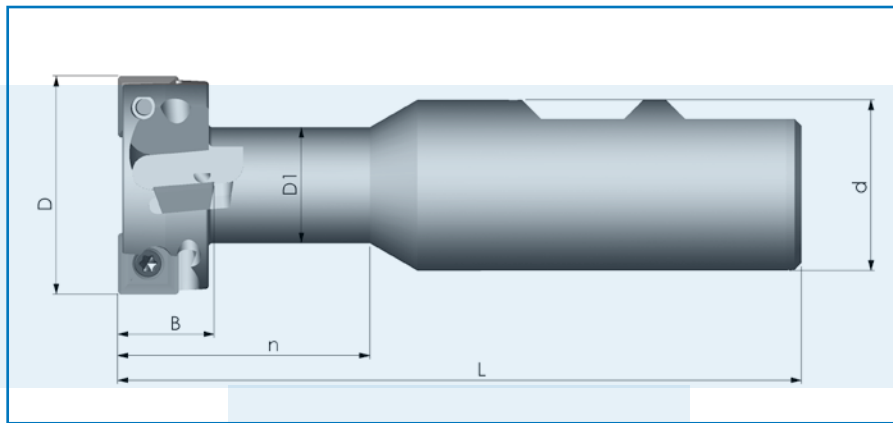



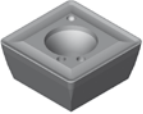
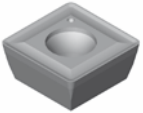
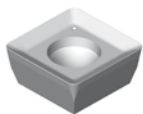
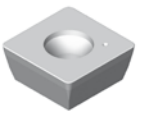

Order-No.	D	D1	B	L	n	d	ZZ	Z
90TN-32-14-328-2	32	17	14	100	37	25	2	4
90TN-40-16-328-2	40	21	16	110	50	25	2	4
90TN-50-21-328-2	50	27	21	130	69	25	2	6

## INSERTS

 9,0x9,0x3,97 r=0,6	FP 327 (B12)	Application areas: 1 - 6 (see page 4)
 9,0x9,0x3,97 r=0,6	FP 328 (B12)	Application areas: 1 - 6 (see page 4)
 9,0x9,0x3,97 r=0,8	FP 332 (B12)	Application areas: 4 & 7 (see page 4)
 9,0x9,0x3,97 r=0,6	FP 348 (B12)	Application areas: 5 & 6 (see page 4)

Type codes: T120=1 TA50=2 SR30=3 P25M=6 HS20=7 K15M=8 TiN-HSSE=9 AL10=10 KD10=11 MG15=12 MG30=13 KT20=14 KT25=15 KD16=16 HT35=19  
Packed in boxes of: 20 pieces

## SPARE PARTS

	SS2,5-1	Fixing screw for FP 65
	SS3,0-2	Fixing screw for FP 327, FP 328, FP 332 und FP 348
	T08	Screwdriver for FP 65
	T09	Screwdriver for FP 327, FP 328, FP 332 und FP 348
	FETT	Heavy duty grease

## APPLICATION AREAS

Material	Cutting speed					
	TA50	HT50	SR30	Ti20	KT25	HT35
<b>1</b> Unalloyed steel Structural steel	150-300	150-350	120-280	200-400	-	-
<b>2</b> Low alloyed steel	100-300	120-320	100-200	200-300	-	-
<b>3</b> High grade steel	150-300	170-320	150-250	180-320	-	-
<b>4</b> Stainless steel Fine steel	80-400	80-400	150-250	-	-	120-250
<b>5</b> Grey cast iron	180-350	180-350	-	200-400	160-300	-
<b>6</b> Grey cast iron with globular graphite	130-250	130-280	-	150-250	160-300	-
<b>7</b> Aluminium Plastics	-	-	-	500-1.000	-	500-1.000
<b>8</b> Hardened steel	-	-	-	-	-	-

Feed rates per tooth	TA50, HT50, SR30	Ti20	KT25	HT35
FP 65	0,05 - 0,25	0,05 - 0,15		
FP 327 / FP 328	0,1 - 0,4	0,1 - 0,3	-	-
FP 348	-	-	0,1 - 0,4	-
FP 332	-	-	-	0,05 - 0,3
FP 330	-	-	-	-

## AVAILABILITY

Ex works, Willich

## Jongen Werkzeugtechnik GmbH & Co. KG

Siemensring 11 · 47877 Willich · Germany  
 Tel: +49 2154 / 9285-0 · Fax: +49 2154 / 911976  
 Free Fax: 00 800 / 56 64 36 33  
 www.jongen.de · email: info@jongen.de

01/07